



LCR4-ID
LCR40-ID

OPERATIONS
MANUAL



POSITIVELY
IDENTIFIES FISH

TABLE OF CONTENTS

INSTALLATION PREPARATION.....	2
Parts Supplied.....	2
Accessories.....	2
Installation Overview.....	2
Alternative Transducers and Mounting Methods.....	4
Transducer Exchange.....	5
INSTALLATION.....	6
Transom Installation.....	6
Inside the Hull Installation.....	10
Control Head Installation.....	12
Test the Installation.....	15
INTRODUCTION.....	16
USING THE LCR 4000.....	19
Total Screen Update®.....	19
Operational Instructions.....	20
Learning to Use Your LCR.....	30
Learning to Read the Display.....	33
MAINTENANCE AND WARRANTY.....	35
Maintenance.....	35
Troubleshooting.....	36
Warranty.....	39
Service Policy.....	40
Customer Support.....	41

TRANSDUCER MOUNTING PROCEDURE

Humminbird's high-speed transducer is supplied with your LCR. This transducer has been designed to give good high speed readings on most all boat designs, including aluminum.

Please carefully consider the following before installing your transducer.

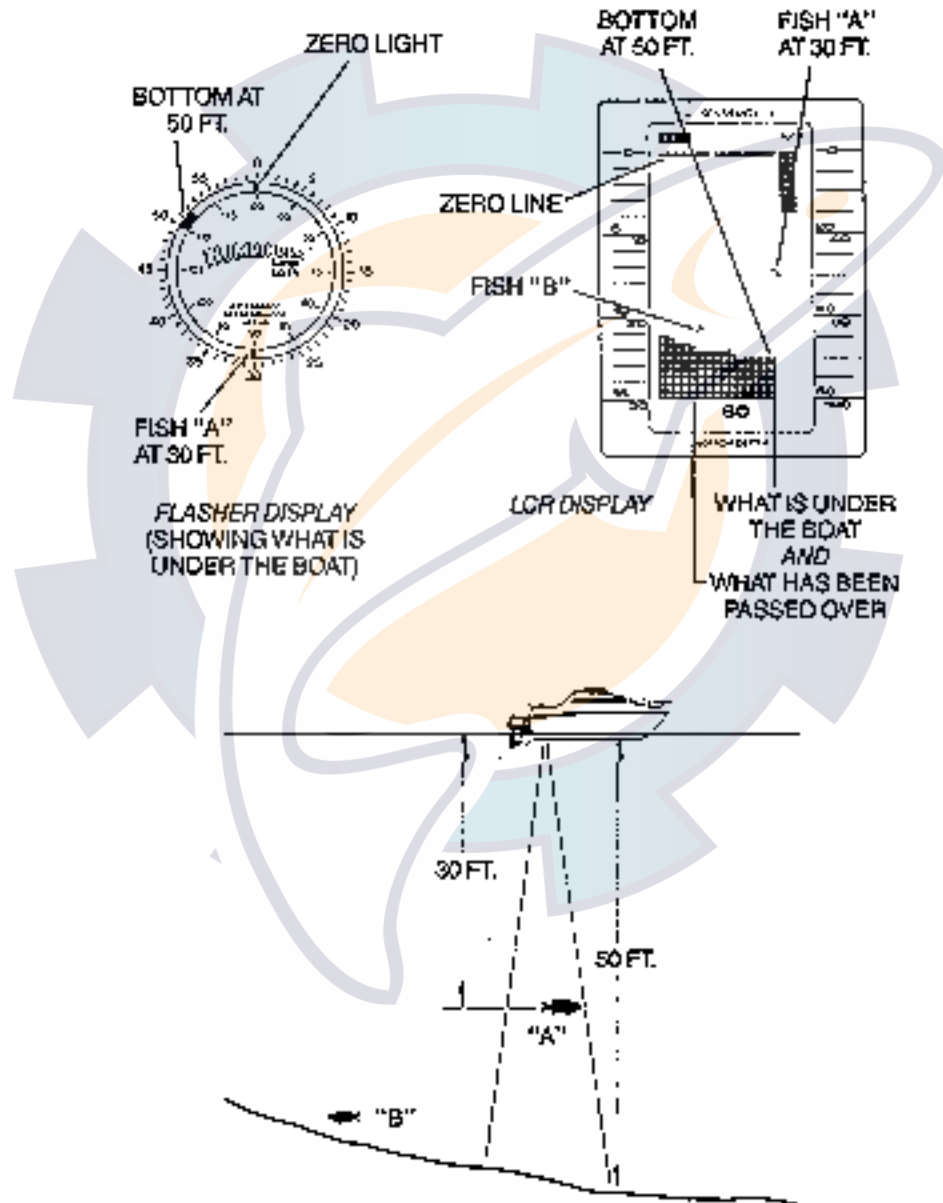

FIGURE 1

TRANSDUCER MOUNTING OPTIONS

A. Transom Mount- The Humminbird high speed transducer allows the transducer

element to be mounted below the bottom of the boat hull keeping the transducer out of turbulent water and insuring good high speed operation. The transducer will absorb the blow of any obstruction by rotating up out of the metal spring bracket without harming the transducer, or your boat. The transducer can be re-engaged by simply rotating the transducer down and snapping it back in place. (See Figure A)

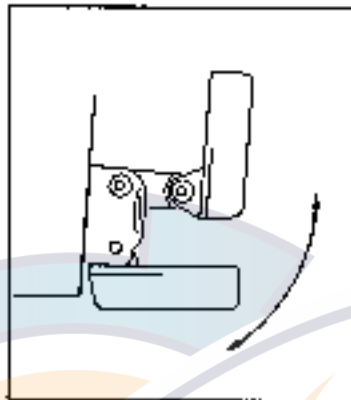

Figure A

- B. Inside Hull Mount- The high speed transducer can be mounted inside the hull (without pivot assembly) using the proper two-part epoxy, such as Humminbird's epoxy kit. Even though there is some loss of signal in shooting through the hull, your LCR will perform well with this type of installation. You cannot shoot through the hull of an aluminum boat.
- C. Trolling motor Mount- This type of transducer is not supplied with your LCR. It is designed to mount on the foot of a trolling motor. You may exchange your un-used high speed transducer for a trolling motor transducer. Call the Humminbird Customer Service Department.
- D. Bronz Thru-Hull Mount- This transducer is not supplied with your LCR but for an additional cost you may exchange your un-used high speed transducer for a bronz thru-hull. The bronz thru-hull transducer has a threaded stem which installs through a hole drilled in the boat hull, leaving the housing exposed under the boat. This type of installation must be used for many boats with in-board engines, because there is no suitable location on the transom away from the noise and turbulence created by the prop. A bronz thru-hull transducer should be installed by qualified personnel only.
The LCR will operate well at high speeds with a properly mounted transducer. Remember, a transducer will not work transmitting through air or through air bubbles.

1. TRANSMOM MOUNTING PROCEDURE

Step 1.

MOUNTING LOCATION- It is important that the transducer be mounted on the transom where water flow is in constant contact with the transducer. You may wish to observe the rear of the boat while it is moving through the water to determine the best mounting location.

Step 2.

BRACKET INSTALLATION (Aluminum Boats)- To install the metal bracket on an aluminum boat locate the template on the transom between rows of rivets, or ribs that are on the bottom of the boat. Align the template so that the bottom corner of the template nearest the center of the transom is on the bottom edge of the transom.

Figure B

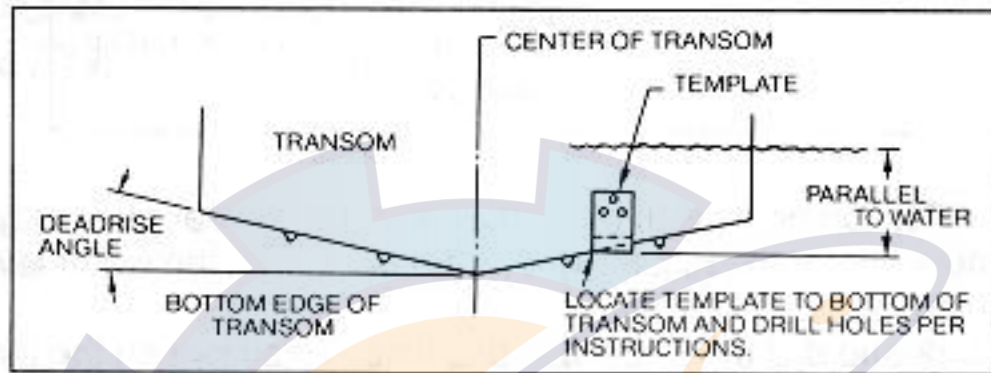

Once the location is determined mark and drill three 7/64" dia. holes noted on the template. Attach the metal bracket using three #10 self threading screws supplied. Be sure to align holes in the center of the Bracket slots. On some aluminum boats it may be necessary to use a wood back-up plate. It is important to use a silicone sealant between the screwhead and bracket in order to prevent leaking. (See Figure C)

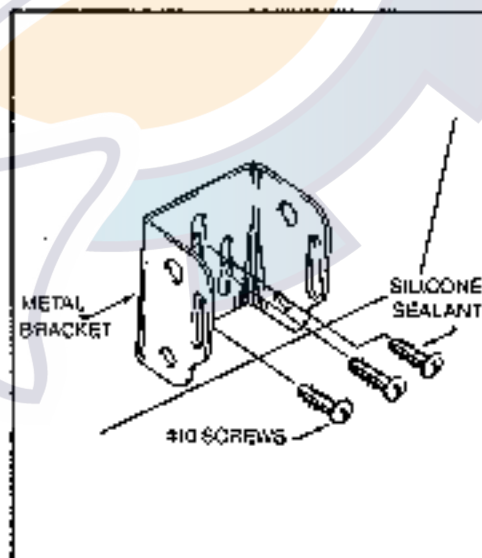

Figure C

Step 2.

BRACKET INSTALLATION (Fiberglass Boats)- If your boat has a stepped transom located below and under the main transom, the compact transducer design allows mounting in this area. This mounting location is recommended for good reading at very high speeds. (See Figure D)

To install the metal bracket on a fiberglass boat, locate the template on the transom in the same manner as for an aluminum boat. (See Figure C)

Figure D

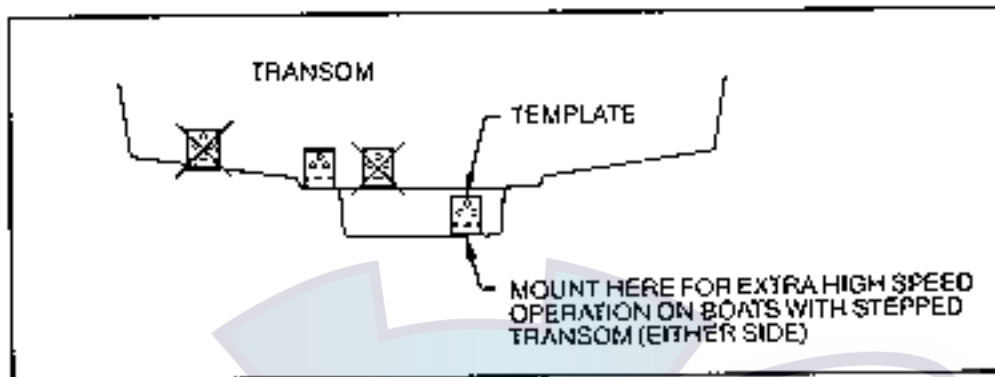

NOTE: On boats with more than 15 degree deadrise angle it may be necessary to mount the transducer slightly off parallel with the water level. (See Figure E)

Mark and drill the three 9/64" dia. holes as shown on the template. Attach the metal bracket using the three #10 self threading screws supplied. Be sure to align the holes so that they are centered vertically in the three slots found in the bracket. It is important to use a silicone sealant between the screwhead and bracket in order to prevent leaking.

Figure E

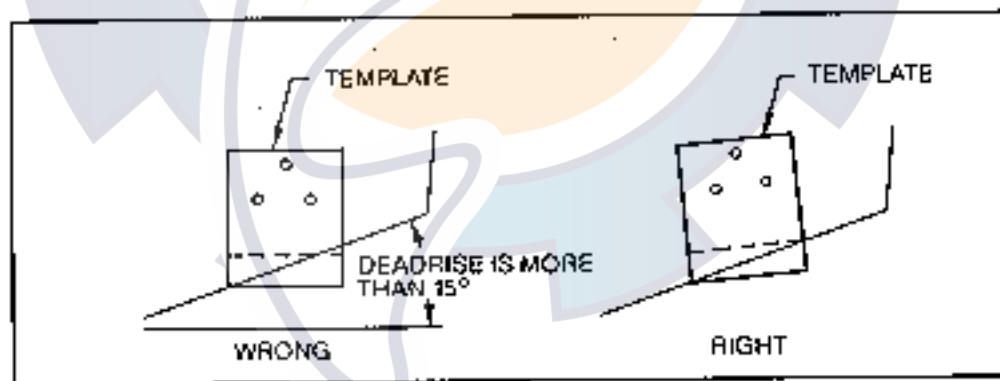

Step 3.

TRANSDUCER PIVOT ASSEMBLY- Assemble the pivot to the transducer main body using the two 1/4"x5/8" allen head screws, two 3/8" tooth washers and two, 1/4" square nuts. Make sure the tooth washers are sandwiched between the transducer main body and the pivot. The square nuts are trapped inside the pivot and will not rotate as the allen head screws are tightened. **HOWEVER, DO NOT TIGHTEN AT THIS POINT.** (See Figure F)

CAUTION: DO NOT APPLY LOCTITE® OR SIMILAR LOCKING COMPOUNDS BECAUSE THEY WILL ATTACK THE PLASTIC.

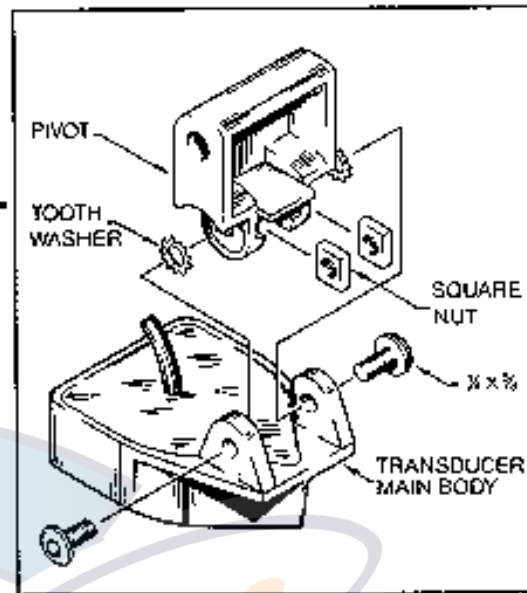

Figure F

Step 4

TRANSDUCER ASSEMBLY- Insert the transducer assembly into the metal bracket from the bottom. Push up until the holes in the plastic pivot align with the uppermost holes in the bracket. Slide the O-ring on to the headed pin and insert it through the two parts. Assemble by screwing the 1/4"x3/8" allen head screw into the end of the pin and tighten. (See Figure G)

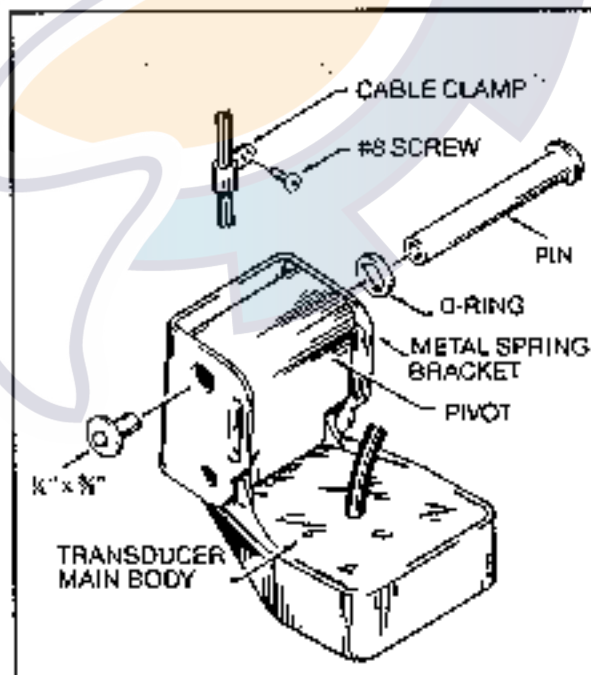

Figure G

Step 5

ANGLE ALLIGHMENT- Set the transducer angle so that it is parallel with the bottom of the boat hull. Once proper alignment is achieved, tighten the two allen head screws

using the 5/32" allen wrench provided. The screws are visible through the access holes on each side of the metal bracket. Check to make sure the transducer main body is rigidly fastened to the pivot. (See Figure H)

Figure H

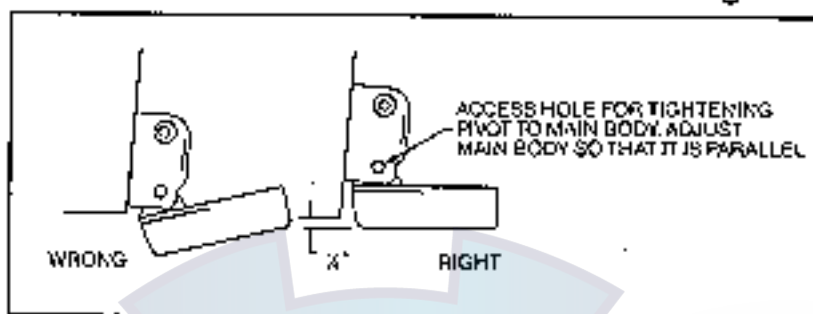

Step 6

CHECK POSITION OF TRANSDUCER- At this point, check to see that the bottom of the transducer is a minimum of 1/4" below the bottom of the transom. (However, as noted in STEP 2, the top of the transducer cannot fall below the bottom of the transom). If it is not, remove the transducer assembly from the metal bracket by removing the pin installed during STEP 3. Loosen the metal bracket mounting screws, re-position the bracket utilizing its slotted holes, tighten and re-assemble. It may be necessary to replace the silicone sealant after this adjustment is made.

NOTE: It may be necessary to make several high speed runs to adjust transducer either UP/DOWN or to re-adjust the angle to achieve optimum results.

Step 7

CABLE CLAMPS- Install cable clamps as necessary by drilling a 1/8" dia. hole for the # 8 screw supplied.

2. INSIDE HULL MOUNTING PROCEDURE

Warning: In order to achieve proper results with this type installation, it is important that the transducer be mounted by someone familiar with the use of two part epoxy adhesives. For this reason, Techsonic Industries, Inc. will not be responsible for any damage due to the mounting of your transducer in this manner.

NOTE: An Epoxy Kit (Part N. EPK) is available from Humminbird. This Epoxy Kit has been formulated for Inside Hull Transducer Installation.

1. Select as flat an area as possible near the aft end and center of boat where the hull is thin and not double. If the bottom has a runner down the center of boat, select an area to one side of the runner, but as close to the runner as possible.
2. Clean the inside of the boat with lacquer thinner in the area transducer is to be mounted. Outside of boat in this area should also be cleaned. (Not with lacquer thinner).
3. Put approximately one inch of water in the bottom of the boat.

4. Put transducer in the water. The bottom of the transducer should be in a flat area and should be in good contact with the bottom of the boat.
5. Operate the LCR with the boat operating at high speed. The transducer may have to be moved in order to find an area where satisfactory operation is observed.
6. When an area is found that produces satisfactory operation, mark the location of the transducer.
7. Remove the water and transducer and clean the marked area and the bottom of the transducer thoroughly.
8. Using the Humminbird Epoxy Kit or equivalent, mix an ample amount of epoxy without causing it to bubble and pour it in the area the transducer is to be mounted. The puddle should be larger than the bottom of the transducer.
9. Coat the bottom of the transducer with epoxy, then put it in the center of the puddle and push down on the transducer while moving it around in a circular motion. This forces out any air bubbles that may be trapped between the bottom of the transducer and the hull of the boat.
10. Let epoxy cure then the transducer is ready to operate. No water is now required in the bottom of the boat and gas and oil that is spilled inside of the boat will not degrade performance as it will if the transducer is placed only in water.
CAUTION: Do not use the silicone seal or any soft adhesive to bond the transducer to the hull. This will reduce the sensitivity of the unit.

CAUTIONS

1. Occasionally the “eye” of your transducer may become dirty from storage or from contact with oils present in boats or marina environments. (Oil will cause the “eye” to lose the intimate contact with the water which is necessary for efficient operation.) The “eye” may be cleaned with liquid detergent.
2. Improper installation of the transducer can alter the efficiency and accuracy of the entire system.
3. If your boat or transducer is out of the water for a period of time, it may take a short period of time for the transducer to become thoroughly “wetted” when returned to the water. Also, re-entry may cause turbulence, which will create air bubbles in the “eye” of the transducer. The bubbles will disappear in a short time or can be removed by rubbing the transducer “eye” with your fingers while the transducer is in the water.
4. If your instrument should fail to function, be sure to check all the electrical connections before removing the transducer or calling a serviceman.
5. Inspect your transducer cable and make sure that it has not been cut or damaged to the point where it will affect the performance of the transducer. A slight nick or cut, exposing the outer cable, can be repaired by wrapping with electrical tape. A transducer can be damaged if the inner cable and outer cable are allowed to make contact. Such a problem can sometimes be corrected by properly splicing the coaxial cable. This should only be attempted by a qualified service technician.
6. If your LCR is not working properly and you suspect the problem might be in your transducer, we would recommend you borrow a unit from a friend and try it on your boat. If the symptoms are the same, you can almost be certain that the problem is in the transducer.

INSTALLING THE LCR

The LCR should be mounted on a flat, solid surface for maximum stability. The low profile swivel mount has four holes drilled in the base. It is recommended that all four holes be used.

Position the swivel base and drill four ¼" diameter holes. Note: The LCR hole pattern is the same as for all Humminbird flasher units. Use hardware provided to mount this base to the boat.

Next place the gimbal bracket on the swivel base and attach with four small machine screws, provided.

Place the LCR in the gimbal mount and make certain the rubber washers provided are placed between the unit and the gimbal bracket. Important: Note which side of the gimbal faces forward. (Slots on gimbal bracket go towards rear). Also, rubber washer must be located between the unit and the gimbal bracket.

Install the mounting knobs and tighten snugly. The unit can now be swiveled and tilted to any desired position.

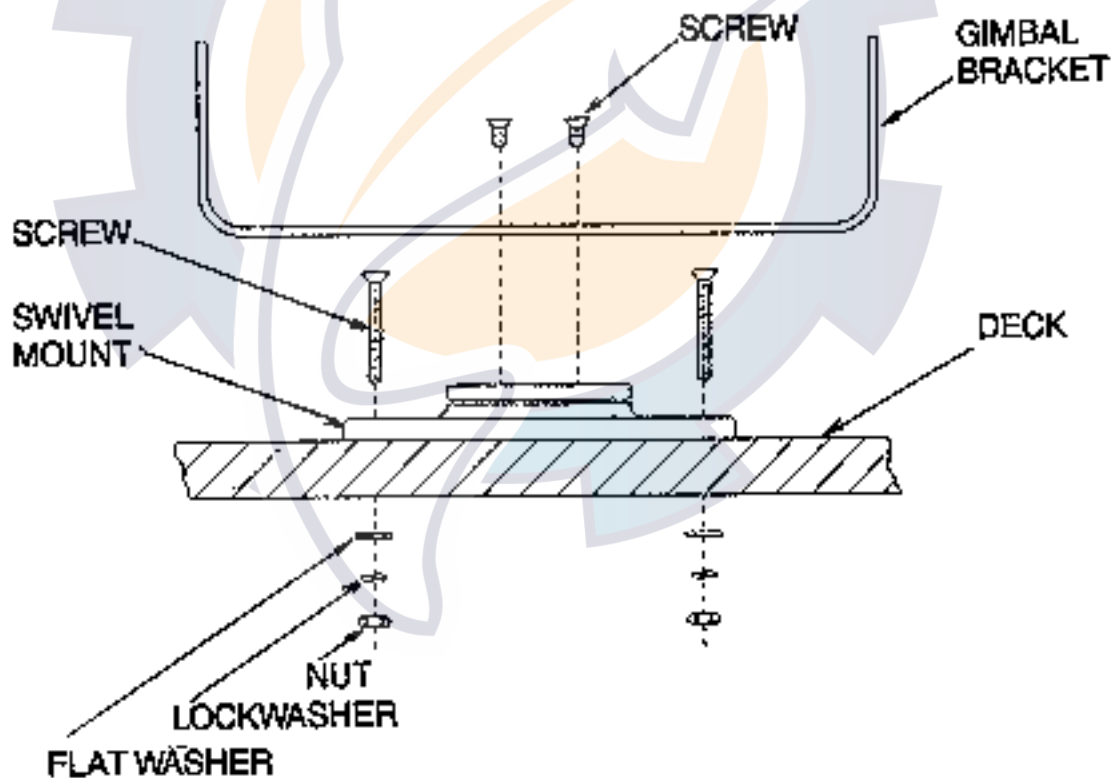

FIGURE 9

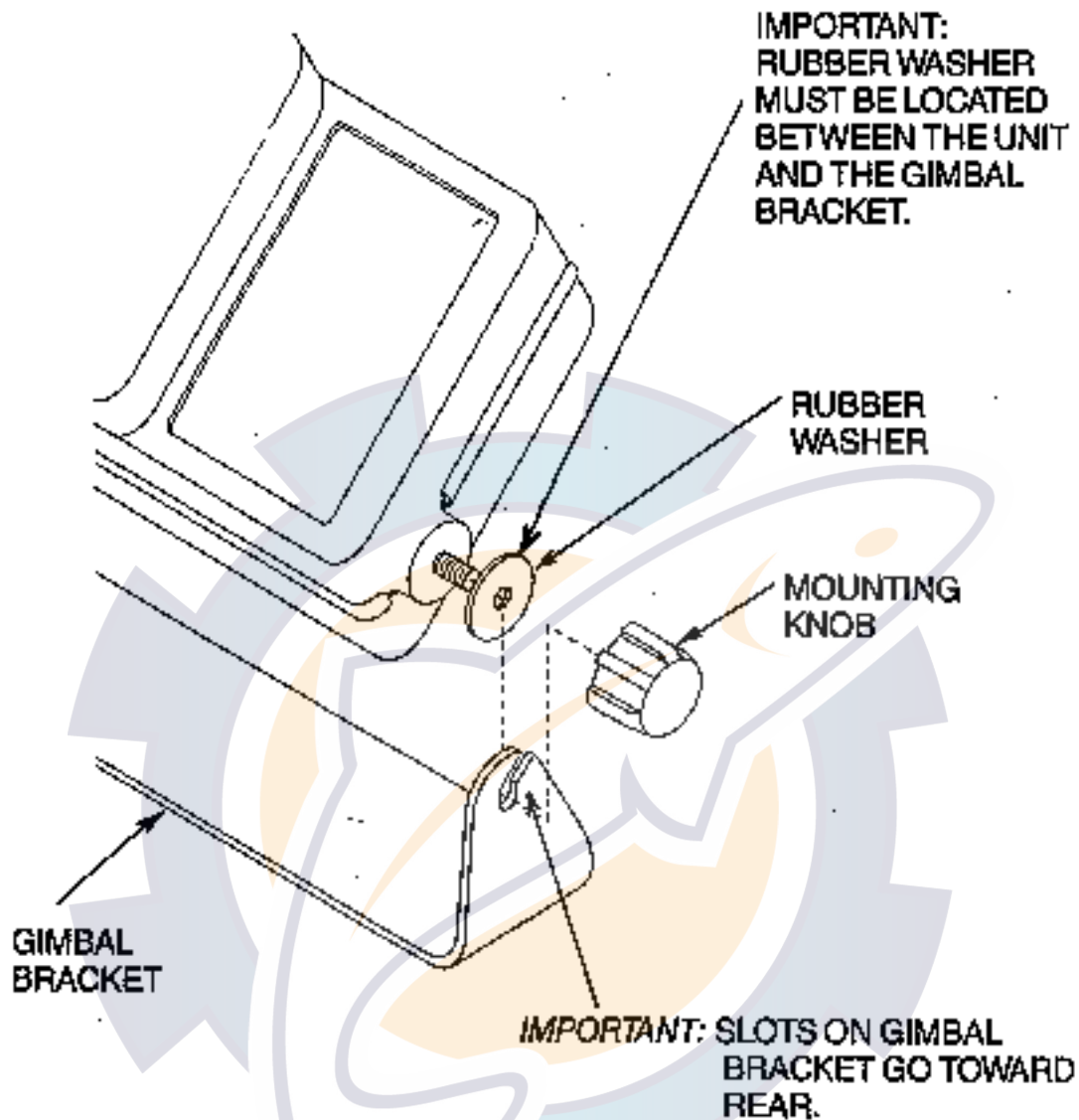

FIGURE 10

OTHER MOUNTING OPTIONS

1. The LCR gimbal bracket can also be mounted on the SM-4, quick disconnect swivel mount.
2. The LCR gimbal bracket can also be mounted directly to the dash without the swivel mount, however, this method is not recommended since the unit cannot be rotated.

INSTALLING THE CABLES

Your LCR comes equipped with Humminbird's new Angle-Lock power and transducer connectors. The power connector is identified with the letter P on the back of the plug. It plugs into the outlet on the back of the unit marked "Power". The transducer connector is identified with the letter T and plugs into the outlet on the back of the unit marked

“Transducer”. Note: An adapter (AD-4) is available to allow use of an old waterproof (BNC) transducer with the LCR, but be sure that the transducer is a 16degree. A 32-degree transducer cannot be used.

A 1 1/8” hole must be drilled to pull through the transducer connector. After drilling the hole, pull the transducer connector up through the hole. If you are installing two units, both transducer connectors can be pulled through this 1 1/8” inch hole. Next, push the power cable wires down through the hole. A hole cover has been provided which will dress and hold the wires. Install the hole cover after determining the necessary wire length from the hole.

The power cable has a red lead to the positive (+) post and the black lead to the negative (-) post. Install a 1 amp fuse between the red cable and positive post of your 12-volt battery.

If a fuse panel is available, we recommend wiring the power cable into the fuse panel. Note: The LCR must be fused separately from any other accessory.

Your Angle-Lock connectors can only be plugged in one way. Position the connector so the letter P or T can be read and the 90 degree bend is pointed downward. Push the connector in as far as it will go. Turn the positive locking ring as far as it will go clockwise until you feel it lock. Locking ring as far as it will go clockwise until you feel it lock. Your connector is now locked into place.

Note: For easy access to the connectors, simply loosen the mounting knobs and tilt your LCR forward. The connectors are now in full view and easy to plug or unplug.

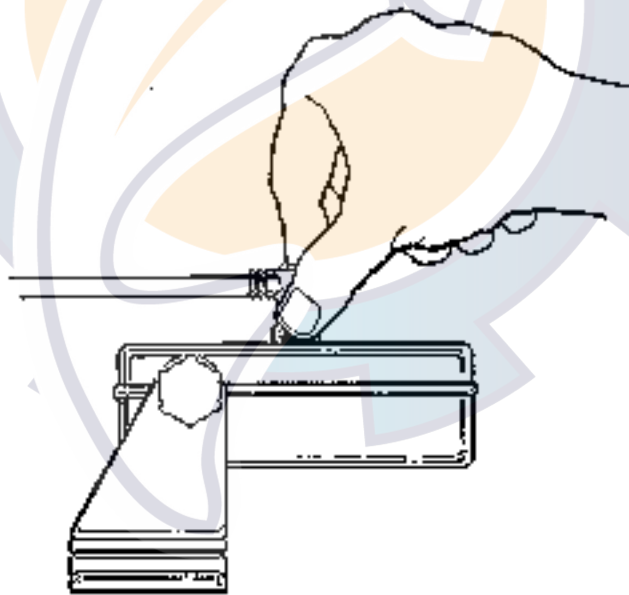

INSTALLATION

TEST THE INSTALLATION

TEST THE INSTALLATION

Testing should be performed with the boat in the water, however you can initially confirm basic operation with the boat trailered.

Press POWER once to turn the unit on. There will be an audible chirp when any button is pressed to confirm the button press. If the unit does not power-up, ensure the unit is fully seated on the mount and that power is available.

The first screen provides four options: Start-up, Options, Simulator, and Diagnostic. A message at the bottom of the screen indicates the transducer connection. If no transducer is detected (or one is not connected), the message will indicate this and the unit will go into simulator after the initial screen times out.

Note: the transducer must be submerged in water for reliable transducer detection.

If a transducer is detected, the unit will enter "Start Up" or normal operation unless you choose another option. If you do not press any button before the timer reaches "0", the normal operation screen is displayed. If the boat is in water, sonar data appears.

If the bottom is visible on screen with a digital depth readout, the unit is working properly. Ensure the boat is in water greater than 2' but less than the depth capability of the unit and the transducer is fully submerged. Remember the sonar signal cannot pass through air.

If the unit is working properly gradually increase the boat speed to test high-speed performance. If the unit-functions well at low speeds but begins to skip or miss the bottom at higher speeds, the transducer requires adjustment. Refer to the appropriate transducer installation section for more detail.

Note: it is often necessary to make several incremental transducer adjustments before optimum high-speed performance is achieved.

Important: For Transom Mount transducer installations, install the third mounting screw after the final transducer adjustments.



USING THE LCR

INTRODUCTION

Before attempting to install or operate your Humminbird LCR, it is recommended that you read the operations manual thoroughly. The LCR4-ID and LCR40-ID have a number of special features not found on other depth sounders. To completely understand all the features of your unit, we suggest you follow the instructions in this manual. If after reading the instructions, there is something you do not completely understand about the operations of your unit, we recommend you contact our customer service department- CALL (334)687-0503.

INTRODUCTION

Congratulations on selecting the LCR4-ID or LCR40-ID. Your unit uses advanced LCR technology to make it easy to use and easy to understand so that you will quickly learn the basics of operating your unit. It also incorporates the most innovative concepts available for finding fish, making it the first true fish finder ever made. Read this operations manual thoroughly for all the outstanding features of your LCR. You will be amazed at its capabilities.

Since there are virtually no moving parts, your LCR will function more trouble free than any sonar unit you have ever owned. This unit has been engineered, tested, manufactured, and is guaranteed by the employee/owners of Techsonic Industries, located on the shores of Lake Eufaula, Alabama.

Fishing, boating, and depth sounders are our business, and at Humminbird we stand behind our product 100%.

Your new LCR is covered by our Lifetime Guaranteed Service policy. We wish you good luck, good fishing, and many hours of pleasure with your new Humminbird LCR.

THEORY OF OPERATION

Your Humminbird LCR works on the basic principals of sonar. An electronic signal is generated within the control head of the unit. When coupled to the transducer, this signal is converted to an ultrasonic signal and is transmitted toward the bottom. The speed of the ultrasonic signal traveling through the waters is approximately 4800 feet per second.

The signal travels through the water until it strikes an object or the bottom. At this instant it is reflected back, picked up by the transducer, reconverted to an electronic signal and is recorded on the display of the LCR.

USING THE LCR

INTRODUCTION

The reading at the far right hand position of the display illustrates that which is being passed over at that time. If you are familiar with a flasher unit, you might think of the information coming on the right side of the screen as the information that would be seen at one instant on a flasher (see Figure 1). However, unlike a flasher, this information is not lost but it is shifted or moved to the left as new information comes on. Therefore, the information is retained until it disappears from the left hand position of the display.

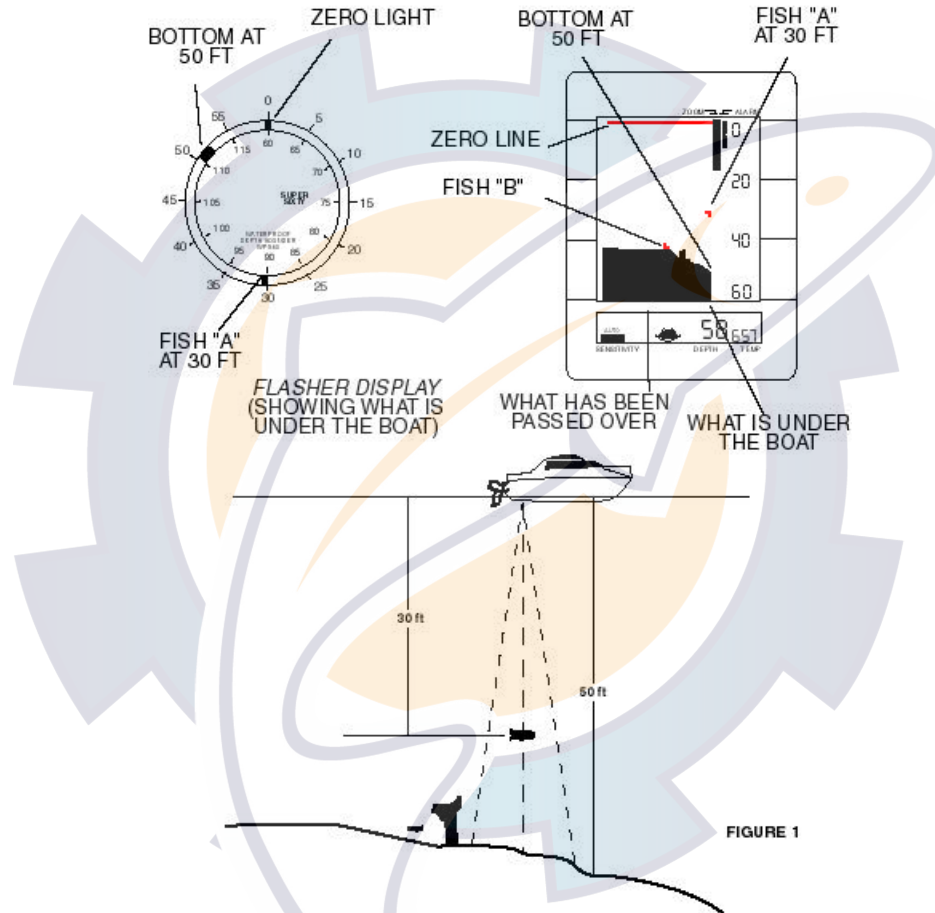

The display used on the LCR is a Liquid Crystal Display. The material in the display is a liquid that can be aligned such that it either "blocks" light or it lets light pass through. This "blocking" of light is what makes the dots on the screen.

Since the LCR's display depends on light passing through it to make the images, increasing the light source will make it easier to see. This is why your LCR can be seen so well in direct sunlight. You will also notice that the display can be seen better at certain angles. The LCR mounting has been designed for tilting and pivoting so that you can easily maintain a good angle for viewing. Another characteristic of an LCR display is that you may find that some polarized glasses might affect the view by causing a rainbow prism to appear. This condition can possibly be improved by a slight adjustment in tint.

USING THE LCR

INTRODUCTION

The LCR4-ID and LCR40-ID use a special and very unique liquid crystal display. Ordinary LCD's have two colors-black and white. The black color, as was explained earlier, is made by blocking the light that comes into the display.

The LCR4-ID and LCR40ID add a third color, red, by using a second layer on the display. If you look closely you will see that the red image is slightly above the black image. You will also notice that the red image is transparent, that is, you can see through it to the black and white image. This new display gives your unit the ability to display more information than ordinary two-color units:

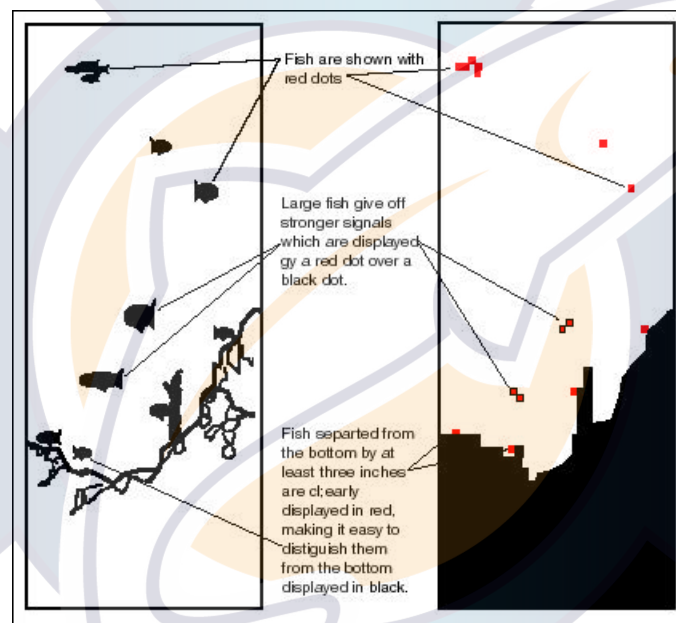

FIGURE 2

1. **Objects at least three inches off the bottom are displayed in red.** The bottom and structure attached to the bottom are displayed in black. The electronics in the LCR4-ID and LCR40-ID can separate the bottom from objects at least three inches off the bottom no matter what depth range you are viewing. This means that fish close to the bottom will be easily seen on the LCR (see Figure 2). These same fish would be missed on an ordinary display because they would just look like part of the bottom.
2. **Strong signals are displayed with a red dot over a black dot.** The electronics can separate the strong fish echoes from the weaker fish echoes. This means that you will be able to find the bigger fish because they will be displayed with a red and black dot, making it easy to separate them from the weaker returns displayed in red only. You will notice a slight pink tint on the display. This is due to the additional layer on the LCD.

USING THE LCR

TOTAL SCREEN UPDATE

TOTAL SCREEN UPDATE®

What is Total Screen Update?

Total screen update is a unique feature of Humminbird LCRs. It will allow you, when changing depth scales, to totally change or update the screen to the new depth scale. It will allow you to zoom in and look at information in much finer detail even after you've already gone over the area.

How Does Total Screen Update Work?

Inside the LCR are memory devices which can store information. Automatically, while you're operating the LCR, the computer is putting information into the LCR'S memory.

All this information is being put into memory in much smaller increments (pieces) than is being displayed on the normal full depth scales. For example, on the 0 to 60 foot scale each dot is equal to one foot of depth, but the computer is putting information into memory such that each dot equals 2½ inches.

If after reading this, you don't understand how Total Screen Update works, don't worry. The important thing is that you understand how to use Total Screen Update. Read on...

How To Use Total Screen Update

This is the easiest part. Since the LCR's computer is doing all the work, you will find the LCR Total Screen Update very easy to use.

There are two ways that you will use Total Screen Update:

1. When changing a depth scale the LCR's computer will automatically change or update the entire screen to the new depth scale. This Total Screen Update feature works when changing to deeper or shallower scales. For example, suppose you are in the 0 to 120 foot scale but the bottom depth changes quickly to 20 feet. When the depth range is changed to the 0 to 30 foot scale, the entire screen will look just as if you had gone over the area on the 0 to 30 foot scale.
2. The second way that you will use Total Screen Update is in operating the LCR's Zoom or Bottom Lock. Since the computer has stored in memory information in very small increments, you will be able to recall this information from memory to get an expanded view of areas which you have already passed over.

USING THE LCR

OPERATIONAL INSTRUCTIONS

For example, if you go over some interesting structure or fish, you will be able to zoom in for a better look without going back over the area. Simply activate the zoom and the information that is stored in memory will be recalled and the total screen will be updated (changed) to show the zoom information. Also, when you go back to the full depth range, the entire screen will be changed to look just as if you had been on that depth range all along.

The operation of the zoom function is explained in a later section.

OPERATIONAL INSTRUCTIONS

The Humminbird LCR will operate fully automatic or manual at the discretion of the operator. At the heart of the LCR are 2 microcomputers which make thousands of decisions every second. With the LCR'S automatic features you will quickly and easily learn the basics of operating your unit, and after a couple of trips on the water you'll be operating the LCR like an expert. It is suggested that you familiarize yourself with each of the features and controls prior to operating your LCR.

1. **Power:** To activate the unit, depress the power "On/Off" switch. The LCR always comes on in the automatic mode. In the automatic mode, the unit will find the bottom by varying the sensitivity and selecting the proper depth range for a satisfactory return. Also, the bottom is blacked out to make the display easier to read.

To turn the unit off, depress the power "On/Off" switch again.

2. **Light:** Depress the light "On/Off" switch to activate the display light for night or low light conditions. The light is turned off by again depressing the "On/Off" switch. When using the night light you will notice that the viewing angle, or best viewing position is different than during daylight operation. Tilt the unit back until you find the best angle for night viewing.

3. **Identification Features:** When the LCR is turned on, the ID (identification-red display) is automatically on. To turn the ID feature off, simply depress the ID on/off button. With the ID feature off, all dots will be black. To turn the ID feature on again, press the ID on/off button.

Notice that the total screen update feature allows you to change the total screen each time you turn the ID feature off or on.

USING THE LCR

OPERATIONAL INSTRUCTIONS

Please read the Theory of Operation in the front of the manual for a detailed explanation of the ID feature. Below are some tips to help you use this advanced ID feature:

- A. The bottom and anything attached to the bottom are displayed in black.
- B. Objects at least three inches off the bottom are displayed in red. This makes it very easy to find fish, particularly those close to the bottom.
- C. In some instances it will be possible to detect inanimate objects not attached to the bottom, such as a floating log or tip of a branch. In this case the return will be displayed in red, because it is not possible to distinguish between animate and inanimate returns.
- D. Strong signals are displayed with a red over a black dot. This makes it easy to find bigger fish because they are easily separated from the weaker returns that are displayed in red only.
- E. A large fish that is directly under the transducer will reflect a stronger signal than the same size fish at the edge of the transmitted signal, as shown in the drawing.
- F. With the LCR's signal strength indicator you can also tell more about schooling fish. A school of fish displayed as a group of red dots with a black core would indicate a very dense school or one that has some large fish. Smaller schooling fish would be displayed in red only.
- G. The LCR4-ID and LCR40-ID identification feature has been designed to be easy-to-use and easy-to-understand. It will add fun to your fishing and give you more fish-finding information.

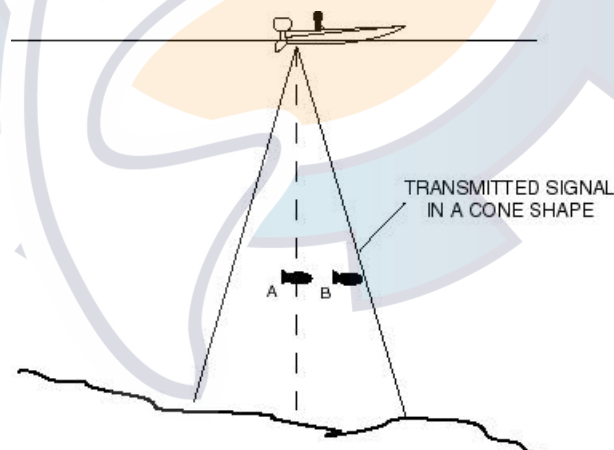

USING THE LCR

OPERATIONAL INSTRUCTIONS

4. Automatic or Manual Mode

Automatic Mode- Each time the unit is turned on, the automatic feature is on. In the automatic mode the sensitivity is adjusted automatically to give a good return and the correct depth range is selected. The word Auto will appear in the lower left corner of the display any time the unit is in the automatic mode. The sensitivity bar at the bottom of the screen will increase or decrease automatically in deciding the amount of sensitivity being used. In deeper water this bar will increase indicating more sensitivity. In shallow water the sensitivity needed to achieve a good return will be less. Also, in the automatic mode, the unit will black out the display beneath the bottom line.

Manual Mode- There are two ways of putting the LCR in the manual mode: (1) depress the Auto "On/Off" button or (2) depress either sensitivity decrease (-) or increase (+) button. You will notice that the word Auto in the lower left corner of the display has gone off. The operator can control the amount of sensitivity by depressing the (+) or (-) button. There are 15 sensitivity settings. When the (+) or (-) button is pressed once the sensitivity setting will change by one division. If the (+) or (-) button is held down the setting will move up or down as long as the button is held down. When the maximum or minimum setting is achieved, the unit will make a "Chirping" sound indicating a limit has been reached.

To once again activate the automatic mode, depress the auto on/off switch.

In the manual mode the depth range does not change automatically. The digital bottom depth is not displayed. The ID feature is on.

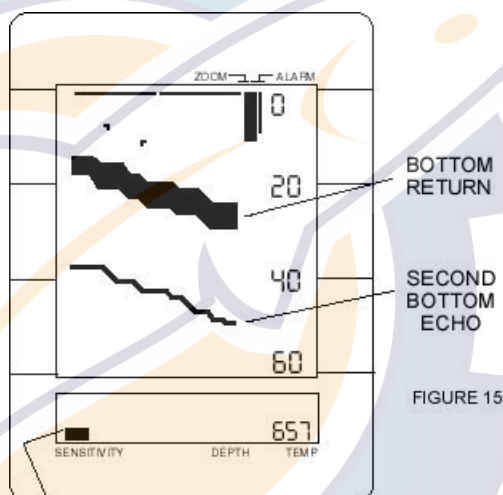

FIGURE 15

"AUTO" OFF INDICATING MANUAL MODE. ALSO NOTE THAT IN MANUAL MODE THE RED ID FEATURE, FISH ALARM, AND DIGITAL BOTTOM READING ARE TURNED OFF.

SOFTER BOTTOM INDICATED BY NARROWER BOTTOM RETURN

HARDER BOTTOM INDICATED BY WIDER BOTTOM RETURN

FIGURE 16

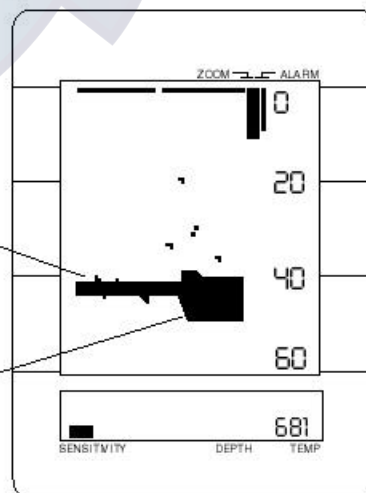

USING THE LCR

OPERATIONAL INSTRUCTIONS

Also, in the manual mode everything below the bottom is no longer blacked out, therefore a second return or double echo can be displayed if desired. (See figure 15). Also, the hardness of the bottom can be determined by the thickness of the bottom return. For example, a hard or rock bottom will give a wider bottom return as compared to a soft or muddy bottom. (See Figure 16).

You should also note that it's possible to have the sensitivity set too high such that reflection off of suspended matter or air bubbles will begin to blackout the display.

5. Zoom and Bottom Lock: You will find the Zoom feature of the LCR to be a very valuable tool. The zoom Range is controlled by the Range Up or Range Down buttons. Each time one of these buttons is depressed the zoom region will move one division. If the button is held down the region will continue to move as long as the button is held down.

The zoom region is indicated by the wide group of bars at the right side of the display. On the LCR4-ID this zoom region is 15 feet wide. On the LCR40-ID the region size may be selected at 15 feet, 30 feet or 60 feet by pressing the Zoom Size button. On the 15 ft. zoom each dot represents 2 1/2 inches, on the 30 ft. zoom each dot is 5 inches and on the 60 ft. each dot is 10 inches.

What Zoom Does

The zoom feature on the LCR will allow you to look at underwater readings in very fine detail, and with the LCR's Total Screen Update you have the capability to zoom in on bottom, fish and structure, even after you have gone over the area.

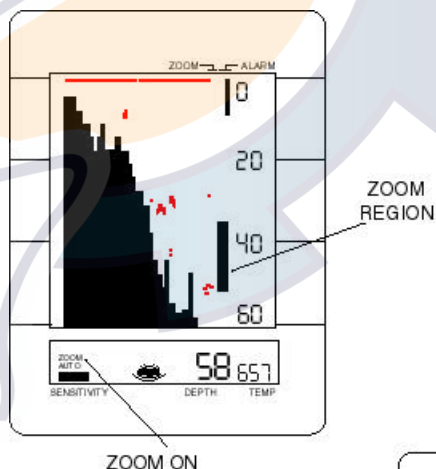

How To Use Zoom

First position the Zoom Region (See Figure 17) next to the area that you want to expand by pressing the Range up or down button. Next, by pressing the Zoom button the zoom will be activated. You will notice that the

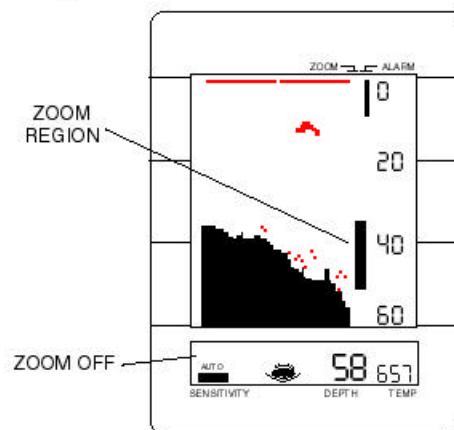

FIGURE 17

USING THE LCR

OPERATIONAL INSTRUCTIONS

word Zoom appears in the lower part of the display, indicating that the Zoom is on. You will also notice that the entire screen has been changed to show an expanded view of the area from the top of the Zoom Range to the bottom of the Zoom Range. The LCR'S Total Screen Update feature allows you to zoom in on an area even after you have passed over it. Figure 17 shows two screens, one with Zoom off and one after turning Zoom on.

The zoom may be activated at any time (during normal transmitting and receiving or stop action), but while learning to use the Zoom feature you might find it easiest to first press the Stop/Resume button to freeze the display. Now you can position the Zoom Range, activate the Zoom, and study the display. By pressing the Zoom On/Off button again you can go back to the un-expanded or normal display. Going back and forth several times will help you in understanding exactly what you are seeing with the Zoom activated.

Some Additional Things You Should Know About Zoom

- A. While the Zoom is turned on you can move the Zoom Range up and down. This will allow you to search or look at an entire area in fine detail.
- B. The Zoom Range indication at the right of the display can be used for depth reference. For example in Figure 17 the Zoom Range is set between 33 feet and 46 feet. This means that when the Zoom is activated that you are looking at an expanded view of the area from 33 feet to 48 feet.
- C. Remember that because of the LCR's Total Screen Update feature the information to the maximum depth is always being recorded in memory. This means that even while you are using Zoom, no information is being lost. You can turn Zoom off, go to any depth scale and see all the information just as if you had been on that depth scale all along

Bottom Lock:

Your LCR has a very unique bottom lock feature. To activate bottom lock, hold down the zoom on/off button for 1 to 2 seconds. The words Bottom Lock in the lower part of the display will come on indicating that it is activated. Bottom lock works very similar to zoom except that the zoom region always stays on the bottom, therefore giving an expanded view up from the bottom. You will notice that as the bottom depth changes, the zoom cursor will also change to maintain its position on the bottom.

USING THE LCR

OPERATIONAL INSTRUCTIONS

In bottom lock the expanded information always comes onto the screen at the same location. However, as the information moves across the screen and as the bottom contour moves up or down, the displayed information will also move so that you can see the actual bottom contour. Remember, in bottom lock, you will be seeing up from the bottom and this expanded area will move up or down as the bottom contour changes.

When the bottom lock is activated, the LCR will change to the lowest depth range, so that the bottom can be tracked to the maximum depth.

6. **Audible Alarms:** The LCR is equipped with two audible alarms, a Fish Alarm and a Bottom Alarm.

Fish Alarm:

The LCR Fish Alarm will give a short alarm sound anytime a return is detected between the boat and the bottom. It will not alarm on the bottom, but only on objects off the bottom.

To activate the Fish Alarm press the Fish Alarm "On/Off" button. The indicator in the lower part of the screen will indicate that the Fish Alarm is on. The Fish Alarm is operational only while the LCR is in the automatic mode. See "Manual Mode" in this section for use of the alarm in the manual mode.

The Fish Alarm may occasionally sound when no target is displayed. This can happen when the display sweep speed is slow such that the target was detected but gone by the time the display is updated.

To turn the Fish Alarm off, simply press the Fish Alarm "On/Off" button again.

Bottom Alarm:

The Bottom Alarm is activated by pushing the alarm "On/Off" button. When first activated the alarm is set at five feet. The desired alarm depth can be adjusted up or down by pressing the depth set button and the increase or decrease button. When the increase or decrease button is pressed once the alarm setting will change one division. If the button is held down the setting will move as long as the button is held down. The alarm setting is indicated down the right side of the display. The Bottom Alarm may be set anywhere from 4 feet to the maximum depth. When the bottom enters the alarm range it will trigger a continuous audible signal.

The Bottom Alarm will operate both in the automatic and manual modes, however the operation is slightly different depending on what mode is on.

USING THE LCR

OPERATIONAL INSTRUCTIONS

Automatic Mode: In the automatic mode a continuous alarm will sound only when the bottom depth is equal to or less than the alarm setting. Fish entering the alarm range will not trigger the alarm unless of course the fish alarm is on.

Manual Mode: In the Manual Mode either the bottom or fish can trigger the alarm. If the bottom depth becomes equal to or less than the alarm setting, a continuous alarm will sound. If a fish enters the alarm range, a short, quick alarm will sound. Since the fish alarm is active only in the automatic mode, positioning the bottom alarm range close to the bottom will allow you to have a fish alarm in the manual mode.

The alarm depth will adjust itself when the depth range changes from one range to another. Thus a depth alarm set at ten feet while on the 30 foot depth range will remain at ten feet deep should the unit advance to any other range. To set the alarm with the most accuracy, set it using the lowest depth range.

Turn off the Bottom Alarm by again pushing the alarm "On/Off" button. The alarm setting will then go to zero. If the alarm is turned on again before the unit is turned off it will still be set at the previous setting.

7. **Display: Stop/Resume:** Anytime during the operation of the LCR, the operator may "freeze" the display by simply pushing the display "Stop/Resume" button. This feature will aid in the learning and interpretation of the signal on your LCR display by giving you time to study the display. The "Stop/Resume" will not change any original settings when once again activated. **Note: Sensitivity and display speed may not be changed while the display is stopped.** When the "Stop/Resume" button is pressed again the unit will resume reading at the immediate point at which the boat is sitting on the water.

8. **Display Speed:** The LCR has a total of eight display speeds. When the unit is turned on the display will be advancing at a medium speed. To increase the display speed depress the button once or hold it down to change rapidly. An audible sound is heard each time the speed is advanced. When the limit has been reached a chirping sound will be heard. At this point the speed will be advancing at its maximum.

To decrease the speed, simply depress the button until the desired advance is reached.

The speed of the boat and display speed will have a large effect on the way information is displayed. You should select the fastest display speed for high speed operation, but use a slower display speed for idle or trolling speed.

USING THE LCR

OPERATIONAL INSTRUCTIONS

9. **Depth:** In the automatic mode, the proper depth range is found as soon as the unit is turned on. As you move into deeper water and the bottom goes off the screen the next deeper depth range will automatically be activated. Also, as you move into shallower water the depth range will automatically change to the next smaller scale. This change is made when the bottom reaches the top 15 pixels, not when the next depth range is reached. For example, on the 12 foot range, the bottom depth must reach about 24 feet before the depth range will change to 60 feet.

You may also manually change the depth scale by pressing the depth set button. Each time this button is decreased the range is decreased by one setting.

Note. Should you attempt to change to a depth scale which is less than the actual bottom depth. The computer will automatically change the depth scale back to the proper position. For example, if you are in 40 feet of water and you change the depth scale to 30 feet, the computer will automatically change back to the 60 foot scale. Remember, in the manual mode the automatic range change is not active.

The depth scale is always displayed at the right side of the display, with increments at one third add at two-thirds for example, on the 60- foot range, the 20-foot and 40-foot depths will also be indicated.

10. **Digital Bottom Reading:** The Digital Bottom Reading is displayed in the lower area of the screen. It will operate while the unit is in the automatic mode. **The Digital Bottom Reading will not be seen while in the manual mode.**

Optional Surface Temperature Gauge or Trolling Speed Indicator

Your LCR is designed to work with an optional surface temperature gauge, Part Number TG-LCR or an optional Trolling Speed Indicator, Part Number TSHLCR. Figure 17A illustrates the three basic parts of these gauges - the cable interconnection between the electronics and the LCR, the electronic housing, and the probe and cable assembly.

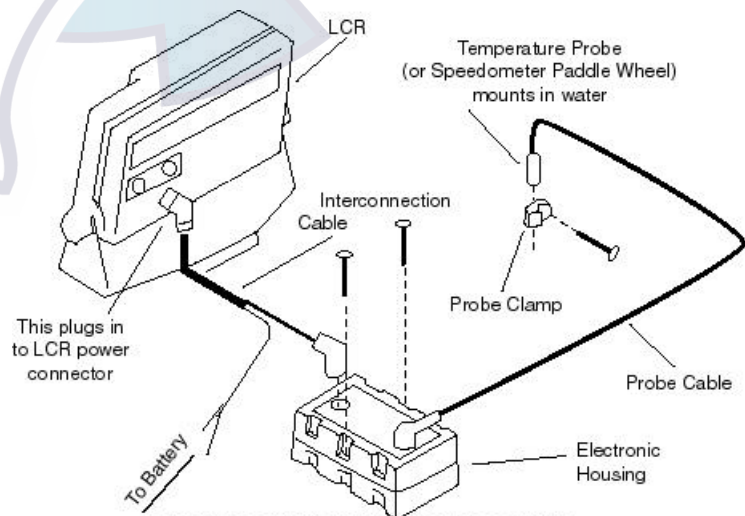

**OPTIONAL SURFACE TEMPERATURE GAUGE
OR TROLLING SPEED INDICATOR**
FIGURE 17-A

USING THE LCR

ADDITIONAL INFORMATION

The surface temperature gauge is a valuable fishing and boating aid. It will measure water temperature in one-tenth of degrees and display the reading on the LCR screen. The probe and computer controlled electronics have been designed for an accurate indication and an extremely fast response time.

The Trolling Speed Indicator will give very accurate low speed readings, in tenths below 10mph, unlike ordinary speedometers. An accurate trolling speed can make the difference in catching fish. The TSLCR also gives accurate high speed readings to 75 mph. If you do not have a surface temperature gauge or a trolling speed indicator, see your LCR dealer or call the Humminbird Customer Service Department's number listed in the front of this manual. If you want both the TG-LCR and TSLCR an accessory switch is available to allow you to use both and select which one is being displayed on the screen.

Simulator

Your LCR has a built in simulator. This simulator will display a typical underwater scene which can be used for demonstration or for learning how to use and understand your unit.

To activate the simulator, the unit must first be turned off. Next, push in the on/off button for one to two seconds, until you hear the chirping sound. Then release the button and the simulated display will begin.

In the simulator mode all buttons can be used. It should be noted, however, that increasing or decreasing the sensitivity setting will not affect the information being displayed.

Some additional things you should know about the LCR.

- Some polarized glasses might affect your view of the LCR display. It could result in a prism or rainbow effect. This condition can possibly be improved by a slight adjustment in tilt.
- *If you get confused* while in the manual mode, for instance, if you don't know where the bottom is, then press the auto on/off button to turn on the automatic mode. The LCR will find the bottom by selecting the proper sensitivity level and depth scale. You can then go back to the manual mode if desired.
- In order for your LCR to operate well at high speeds, you must have a *properly mounted transducer*. Please read the transducer mounting procedure carefully.
- The transducer for the LCR is a 16° just like most standard Humminbird flasher units. Other transducers, such as 32°, *cannot* be used.

USING THE LCR

ADDITIONAL INFORMATION

CARING FOR YOUR LCR

Since your Humminbird LCR is completely waterproof, it can be cleaned with soap and water or hosed off after salt water use with no fear of damage to the unit or its electronics. When cleaning the lens, it is suggested you use a chamois cloth and a non-abrasive cleaner such as Windex. Do not wipe while dirt or other gritty material is on the lens. **Care should be exercised to avoid scratching the lens.** Keep chemicals such as bug repellent, ammonia or gasoline away from the LCR case and lens.

As with any electrical instrument, do not leave your LCR on the dash board or rear window area of the car. The sun can create extremely high temperatures which can damage the case and internal electrical components. During extended periods of non-use, such as winter, you should store the LCR and other removable depth sounders in the house or garage. This will help prolong the good appearance and operation of these instruments.

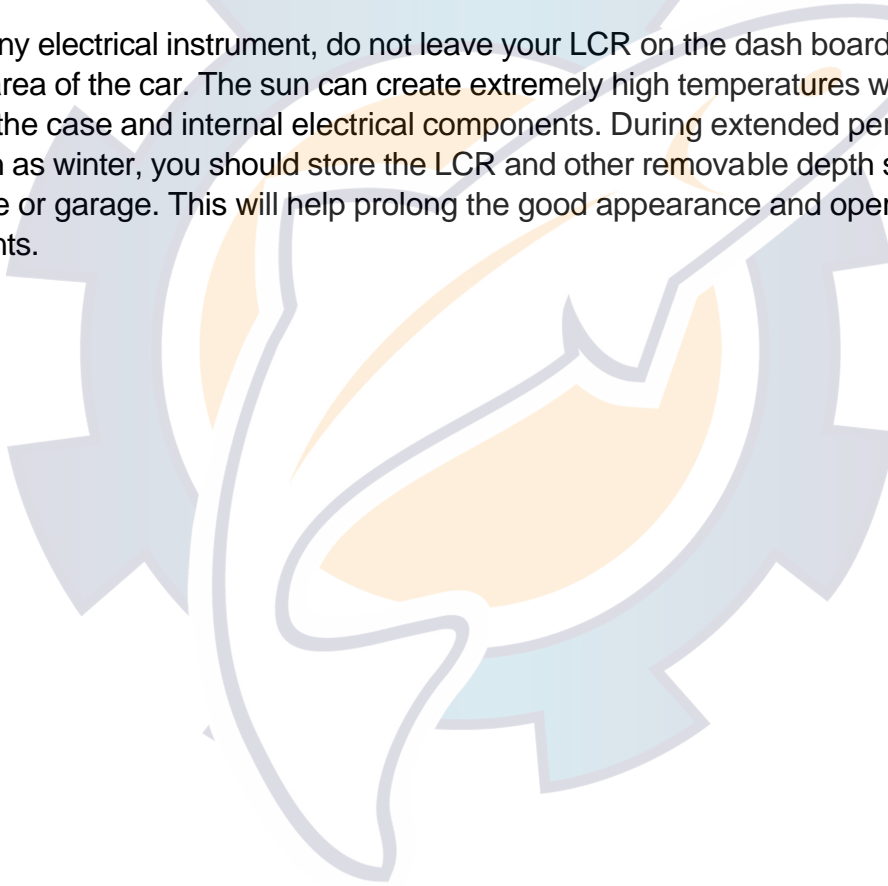

USING THE LCR

LEARNING TO USE YOUR LCR

LEARNING TO USE YOUR LCR

After installing the unit, transducer, and power cable as instructed, the LCR is ready for use. By following the steps below you will be able to quickly learn how to use the LCR. Also, trouble shooting suggestions are listed in these steps. Note: Perform steps 1 through 7 at idle or slow speed. These steps will insure that your LCR is working properly.

Step 1

Turn your LCR on by pushing the "On" button. The LCR'S computer will automatically adjust the sensitivity and depth scale so that in about one second you will see images appear on the right side of the display and moving to the left. The small gap in the zero line allows you to see movement on the display even when the bottom is not changing.

TROUBLE SHOOTING: If nothing happens when the "On" button is pushed, check your electrical connections and fuse. Also check that the red wire on the power cable is connected to the positive battery terminal and that the black wire is connected to the negative battery terminal. If these wires are reversed it will not damage the LCR.

It is normal if when reversing the boat, the bottom return is lost, since air from the prop is being forced under the transducer- remember the transducer cannot transmit through air.

TROUBLE SHOOTING: If the display comes on when the "On" button is pushed but no bottom information is seen, check that the transducer connector is securely locked to the rear of the LCR. Also insure that the transducer is completely submerged. A transducer cannot work properly in air or through air bubbles in the water.

TROUBLE SHOOTING: In very shallow water, the bottom reading might have gaps or the scale might change to a deeper scale This is normal in one or two feet of water. The automatic mode cannot "lock" onto the bottom in very shallow water.

Step 2

Still moving at a slow speed, begin going toward deeper water. You will see that the LCR will display changes as small as 3 inches. Continue to move into deeper water until the bottom return moves off the display. The LCR will automatically change to the next deeper depth scale (indicated at bottom of the display). Notice that the entire screen is changed to the new depth scale. This is the Total Screen Update feature.

USING THE LCR

LEARNING TO USE YOUR LCR

Step 3

Press the depth set button once to change to the next lowest range. If the bottom is deeper than this range, the computer will automatically change back to the proper range. By pressing the depth set button three or four times you will see that the depth range will change. Next Change to the shallowest range. If the water is deeper than that range the depth range will change to the correct setting.

Step 4

Press the Stop/Resume button to lock the display. Move the Zoom Range down by holding down the button and position it down to the bottom of the water. Next, activate the Zoom by pressing the Zoom On/Off button. You will see that the entire screen has changed to give you a much more detailed view. Press the Zoom on/off button a few times to go back and forth so that you can get a better understanding of exactly what you are seeing. (You do not have to stop the display to use Zoom, but at first it is probably easier to learn this way).

With Zoom on, move the Zoom Range up and down. This is how you can search up and down an entire area.

Step 5

Press the Auto Sensitivity on/off button to change to the manual mode. Notice that the word AUTO in the lower left hand corner of the display has gone off. Also, the area below the bottom is no longer blacked out. You can now change the sensitivity setting by pressing the increase or decrease buttons. Notice that the digital bottom reading and the I.D. feature go off in the manual mode. Note: in the manual mode the depth scales will not automatically change. The automatic depth change works only in the automatic mode.

Push the Auto On/Off button to go back to the automatic mode.

Step 6

Press the alarm on/off button to turn on the bottom alarm. Next press the range down () button until the alarm setting is lower than the bottom reading. A continuous alarm will be heard indicating that the bottom depth is equal to or less than the alarm setting. Press the alarm on/off button to turn the alarm off.

USING THE LCR

LEARNING TO USE YOUR LCR

Step 7

Press the Fish Alarm on/off button. Notice the indicator in the lower part of the screen indicating the Fish Alarm is on. Now if an object is detected between the surface and the bottom, a short alarm sound will be heard. By pressing the Fish Alarm on/off button again the Fish Alarm is turned off.

Step 8

Steps 1 through 7 have verified that your LCR is working properly. You are now ready to increase boat speed **to test the transducer installation**. As you increase boat speed the LCR should give a continuous bottom return. With a proper transducer installation your LCR will perform well at speeds over 75mph.

TROUBLE SHOOTING: If at high speeds the bottom return is not continuous or there are gaps in the bottom, then the transducer installation or location is such that air is going under the transducer face. Remember that a transducer cannot work properly through air or through air bubbles in the water. Refer back to the transducer mounting procedure for adjustments or for the other mounting options.

TROUBLE SHOOTING: If when making a hard turn, the bottom reading is lost, it is the result of the transducer coming out of the water during the turn.

USING THE LCR

LEARNING TO READ THE DISPLAY

LEARNING TO READ THE DISPLAY

The following illustrations show some typical display with bottom, structure, and target returns. These should help you in interpreting the information being displayed on your LCR.

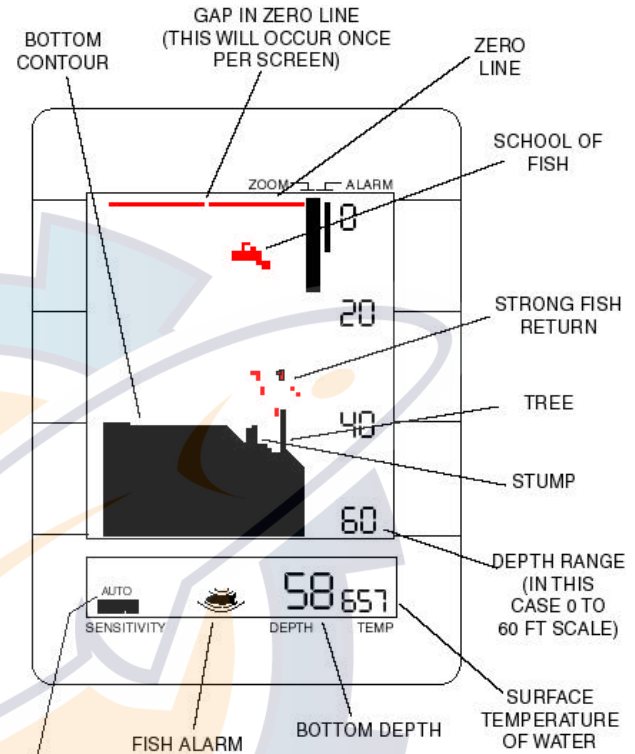

FIGURE 18

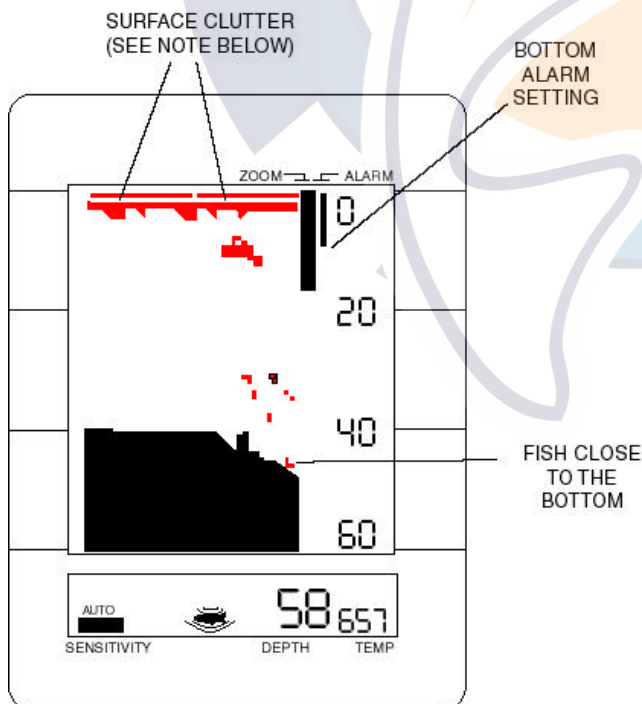

FIGURE 19

Surface clutter: The STC in your LCR will normally eliminate surface clutter, however, in some water conditions or when going across the wake of a boat the surface clutter will appear as shown above.

USING THE LCR

LEARNING TO READ THE DISPLAY

Brush or thick standing timber will appear as a thick mass with holes or gaps as shown above. Notice how the strong fish returns (red dots with black behind) can be easily distinguished.

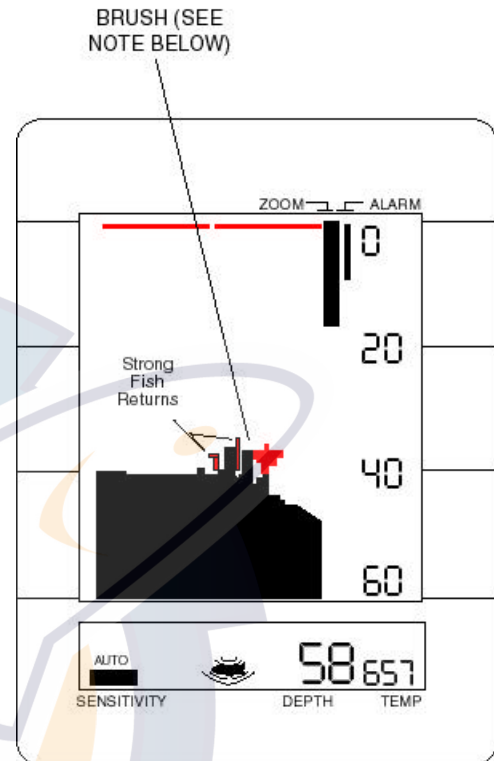
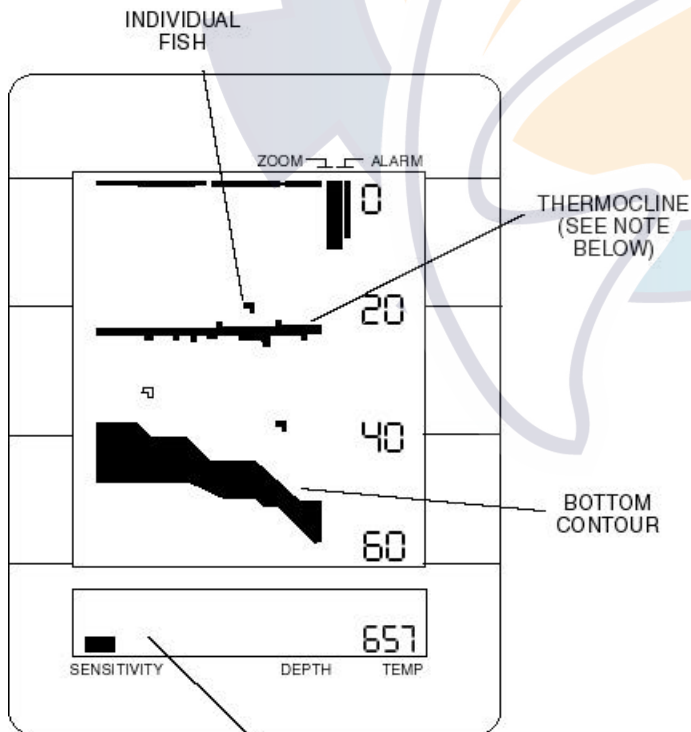

FIGURE 20



"AUTO" OFF
INDICATING
MANUAL
MODE

FIGURE 21

Thermocline is a temperature change at a certain depth in the water. In some conditions the sonar waves will actually reflect or bounce off this temperature change and therefore it will be displayed on the LCR as shown above. To see the thermocline, you will need to go to the manual mode and increase the sensitivity setting.

One of the best ways to learn to use your LCR is to go over familiar locations. If you know what's under the water and can see it displayed on the LCR then you're on your way toward gaining the experience you need.

MAINTENANCE AND WARRANTY

MAINTENANCE

MAINTENANCE

Your Humminbird fishfinder is designed to provide years of trouble free operation with virtually no maintenance. Follow these simple procedures to ensure your Humminbird continues to deliver top performance.

- If the unit comes into contact with salt spray simply wipe the affected surfaces with a cloth dampened in fresh water. Do not use a chemical glass cleaner on the lens. Chemicals in the solution may cause cracking in the lens of the unit.
- When cleaning the LCD protective lens, use a chamois and non-abrasive, mild cleaner. Do not wipe while dirt or grease is on the lens. Be careful to avoid scratching the lens.
- If your boat remains in the water for long periods of time, algae and other marine growth can reduce the effectiveness of the transducer. Periodically clean the face of the transducer with liquid detergent. Pivoting the transducer up in the bracket may allow better access for inspection or cleaning.
- If your boat remains out of the water for a long period of time, it may take some time to wet the transducer when returned to the water. Small air bubbles can climb to the surface of the transducer and interfere with proper operation. These bubbles dissipate with time, or you can wipe the face of the transducer with your fingers after the transducer is in the water.
- Never leave the fishfinder in a closed car or trunk - the extremely high temperatures generated in hot weather can damage the electronics.

MAINTENANCE AND WARRANTY

TROUBLESHOOTING

TROUBLESHOOTING

Do not attempt to repair the fishfinder yourself. There are no user serviceable parts inside, and special tools and techniques are required for reassembly to ensure the waterproof integrity of the housing. Repairs should be performed only by authorized Humminbird technicians.

Many requests for repair received by Humminbird involve units that do not actually need repair. These units are returned “no problem found.” If you have a problem with your Humminbird, use the following troubleshooting guide before calling Customer Support or sending your unit in for repair. Your Humminbird fishfinder contains several tools that can aid in determining if there is a problem and how to isolate and repair the problem in many cases.

1. Nothing happens when I turn the unit on.

Check the power cable connection at both ends. Be sure the cable is connected correctly to a reliable power source - red lead to positive, black lead to negative or ground. Ensure the power available at the mount is between 10 and 20 VDC. If the unit is wired through a fuse panel, ensure the panel is powered. Often accessory fuse panels are controlled by a separate switch or the ignition switch. Also, often a fuse can appear to be good when in fact it is not. Check the fuse with a tester or replace it with a fuse known to be good.

Check the power connection to the unit. It is possible to force the power cable connector into the cable holder incorrectly. If the connector is reversed, the unit will not work. Examine the contacts on the back of the unit to ensure there is no corrosion. Finally, ensure the unit is firmly seated on the mount. The electrical contacts are not made until the unit is fully seated.

Ensure the metal cable retainer is properly installed in the mount. If not, the power connected may push out when the unit is put on the mount.

2. There is no transducer detected.

Most Humminbird fishfinders have the ability to detect and identify that a transducer is connected. If at power up, a message indicates “transducer not connected,” only simulator operation is possible. First, ensure that an appropriate transducer connector is positioned correctly in the connector holder, and that the unit is fully seated on the mount. Your Humminbird fishfinder will work only with an appropriate transducer; check the accessory guide for compatibility.

MAINTENANCE AND WARRANTY

TROUBLESHOOTING

Second, inspect the transducer cable from end to end for breaks, kinks, or cuts in the outer casing of the cable. Also ensure the transducer is fully submerged in water. If the transducer is connected to the unit through a switch, temporarily connect it directly to the unit and try again. If none of these items identifies an obvious problem, the transducer itself is probably the problem. Be sure to include the transducer if returning the unit for repair.

3. There is no bottom reading visible on the display.

There are a number of possible causes for this condition. If the loss of bottom information occurs only at high boat speeds, the transducer needs adjusting. If the digital depth readout is working but there is no bottom visible on-screen, it is possible the depth range has been adjusted manually to a range lower than what is needed to display the bottom. Also, in very deep water, it may be necessary to manually increase the sensitivity setting to maintain a graphic depiction of the bottom.

If you are using a transducer switch to connect two transducers to the unit, ensure the switch is in the correct position to connect a transducer that is in water. (If a trolling motor transducer is selected and the trolling motor is out of water, no sonar information appears.)

If none of the above solve the problem, inspect the transducer cable from end to end for breaks, kinks, or cuts in the outer casing of the cable. If the transducer is connected to the unit through a switch, temporarily connect it directly to the unit and try again. If none of these items identifies an obvious problem, the transducer itself may be the problem. Be sure to include the transducer if returning the unit for repair.

4. When in very shallow water, I get gaps in the bottom reading and inconsistent digital depth indication.

Your Humminbird fishfinder will work reliably in water 2' (.6m) or deeper. The depth is measured from the transducer, not necessarily from the surface.

MAINTENANCE AND WARRANTY

TROUBLESHOOTING

5. The unit comes on before I press POWER, and won't turn off.

Check the transducer cable. If the outer jacket of the cable has been cut and the cable is in contact with bare metal, you need to repair the cut with electrical tape. If there is no problem with the cable, disconnect the transducer from the unit and see if the problem is corrected, to confirm the source of the problem.

6. I get gaps in the reading at high speeds.

Your transducer needs adjusting. If the transducer is transom-mounted, there are two adjustments available to you - height and running angle. Make small adjustments and run the boat at high speeds to determine the effect. It may take several tries to optimize high speed operation. This can also be a result of air or turbulence in the transducer location caused by rivets, ribs, etc.

7. My unit loses power at high speeds.

Most Humminbird fishfinders have over-voltage protection that turns the unit off when input voltage exceeds 20 VDC. Some outboard motors do not effectively regulate the power output of the engine's alternator and can produce voltage in excess of 20 volts when running at high RPMs. Your fishfinder displays input voltage in the Diagnostic screen. Use this readout to determine if the voltage exceeds 20 VDC.

8. The screen begins to fadeout. Images are not as sharp as normal.

Check the input voltage using Diagnostic. The fishfinder will not operate on input voltages below 10 VDC.

9. The display shows many black dots at high speeds and high sensitivity settings.

You are seeing noise or interference caused by one of several sources. Noise can be caused by other electronic devices. Turn off any nearby electronics and see if the problem goes away. Noise can also be caused by the engine. If engine noise is causing the interference, the problem will intensify at higher RPMs. Increase the engine speed with the boat stationary to isolate this cause. Propeller cavitation can appear as noise on-screen. If the transducer is mounted too close to the propeller, the turbulence generated can interfere with the sonar signal. Ensure that the transducer is mounted at least 15" (38cm) from the prop.

MAINTENANCE AND WARRANTY

WARRANTY

HUMMINBIRD ONE YEAR FULL WARRANTY

First year repairs (from original date of purchase) on your Humminbird fishfinder are absolutely free. This does not include physical damage to the unit or its accessory items. Any modification or attempt to repair the original equipment or accessories by unauthorized individuals will void the warranty. Return the warranty registration card and retain your bill of sale for warranty verification. Accessories not manufactured under the Humminbird trade name are not covered by our warranty. **The customer is responsible for shipping charges to Humminbird.** Humminbird will provide ground UPS or Parcel Post shipping back to the customer free of charge. This warranty applies to the original purchaser only.

This warranty is in lieu of all other warranties expressed or implied and no representatives or persons are authorized to provide for any other liability in connection with the sale of our products. Humminbird reserves the right to perform modifications or improvement on its products without incurring the obligation to install the changes on units previously manufactured, sold, delivered, or serviced.

THIS IS A FULL WARRANTY AS DEFINED BY THE FEDERAL WARRANTY ACT EFFECTIVE JULY 4 1975.

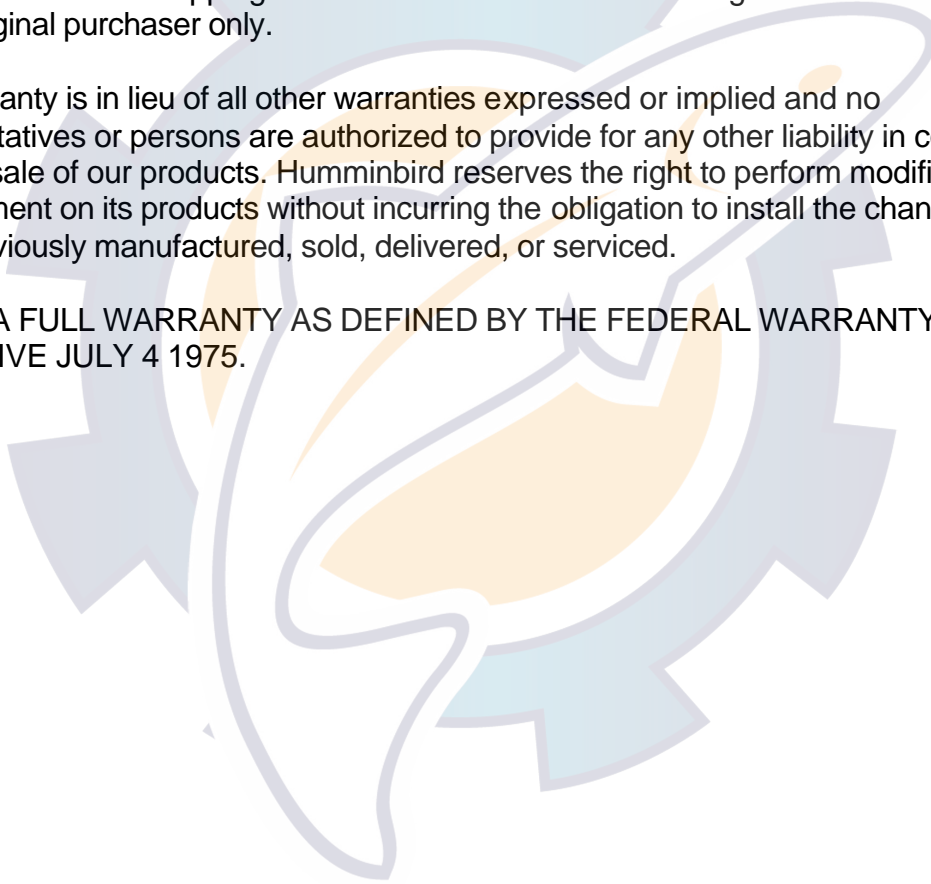

MAINTENANCE AND WARRANTY

SERVICE POLICY

SERVICE POLICY

This Service Policy is valid in the United States only. This applies to Humminbird units returned to our factory in Eufaula, Alabama, and is subject to change without notice.

All repair work is performed by factory-trained technicians to meet exacting factory specifications. Factory serviced units go through the same rigorous testing and quality control inspection as new production units.

Even though you'll probably never need to take advantage of our incredible service guarantee, it's good to know that we back our unit this well. We do it because you deserve the best. We will make every effort to repair your unit within three working days from the receipt of your unit. This does not include shipping time to and from our factory. Units received on Friday are usually shipped by Wednesday, units received Monday are usually shipped by Thursday, etc.

We reserve the right to deem any product unserviceable when replacement parts are no longer reasonably available or impossible to obtain.

After the original warranty period, a standard flat rate service charge will be assessed for each repair (physical damage and missing parts are not included). Please call our Customer Support Department to verify the service charge for your unit.

The standard service charge includes UPS or Parcel Post freight only. If charges are not prepaid, the unit will be returned COD. If you are experiencing problems related to bottom or depth readings please send your transducer along with your unit when sending for repair.

MAINTENANCE AND WARRANTY

CUSTOMER SUPPORT

CUSTOMER SUPPORT

If you have any questions, call our
Humminbird Customer Support Hotline: **1-334-687-0503**

Throughout the U.S. and Canada, hours are Monday-Friday, 8:00 a.m. to 5:00 p.m.
Central time.

If after reading "Troubleshooting" you determine your unit needs factory service, please
attach a description of the problem and send it with the unit to the address below.

If you are including a check please attach it to the unit.

**Humminbird
Service Department
Three Humminbird Lane
Eufaula, AL 36027
USA**

